

OPERATOR'S MANUAL

for

DTCK80/DCTD80KC/DCWD80KC Series Dryers

The dryer must not be stored or installed where it will be exposed to water and/or weather.

WARNING: For your safety the information in this manual must be followed to minimize the risk of fire or explosion or to prevent property damage, personal injury or loss of life.

Do not store or use gasoline or other flammable vapors and liquids in the vicinity of this or any other appliance.

– WHAT TO DO IF YOU SMELL GAS

- Do not try to light any appliance.
- Do not touch any electrical switch; do not use any phone in your building.
- Clear the room, building or area of all occupants.
- Immediately call your gas supplier from a neighbor's phone. Follow the gas supplier's instructions.
- If you cannot reach your gas supplier, call the fire department.

– Installation and service must be performed by a qualified installer, service agency or the gas supplier.
Post the following "For Your Safety" caution in a prominent location:

FOR YOUR SAFETY

Do not store or use gasoline or other flammable vapors or liquids in the vicinity of this or any other appliance.

It is important that you read this Manual and retain it for future reference. For service or replacement parts, contact the distributor in your area or the manufacturer.

AVERTISSEMENT. Assurez-vous de bien suivre les instructions données dans cette notice pour réduire au minimum le risque d'incendie ou d'explosion ou pour éviter tout dommage matériel, toute blessure ou la mort.

Ne pas entreposer ni utiliser d'essence ni d'autres vapeurs ou liquides inflammables dans le voisinage de cet appareil ou de tout autre appareil.

– QUE FAIRE SI VOUS SENTEZ UNE ODEUR DE GAZ:

- Ne pas tenter d'allumer d'appareil.
- Ne touchez à aucun interrupteur. Ne pas vous servir des téléphones se trouvant dans le bâtiment où vous vous trouvez.
- Évacuez la pièce, le bâtiment ou la zone.
- Appelez immédiatement votre fournisseur de gaz depuis un voisin. Suivez les instructions du fournisseur.
- Si vous ne pouvez rejoindre le fournisseur de gaz, appelez le service des incendies.

– L'installation et l'entretien doivent être assurés par un installateur ou un service d'entretien qualifié ou

POUR VOTRE SÉCURITÉ

Ne pas entreposer ni utiliser d'essence ni d'autres vapeurs ou liquides inflammables dans le voisinage de cet appareil ou de tout autre appareil.

You, the purchaser, must post in a prominent location instructions to be followed in the event the user smells gas. Consult your local gas supplier for procedure to be followed if the odor of gas is present.

Dexter Laundry, Inc.

2211 W. Grimes

Fairfield, Iowa 52556 USA

TABLE OF CONTENTS

	PAGE NO.
DRYER DIMENSIONS (Figure 1).....	3
UNCRATING.....	4
DRYER INSTALLATION.....	4
DRYER EXHAUST SYSTEM (Figure 2).....	6
DRYER SHUTDOWN.....	7
OPERATING INSTRUCTIONS.....	8
PROGRAMMING THE DRYER.....	9-14
SERVICING DRYER.....	15
PREVENTATIVE MAINTENANCE.....	15

WARNINGS ABOUT USE AND OPERATION

It is **ABSOLUTELY ESSENTIAL** that the dryer be grounded to a known earth (zero) ground. This is not only for personal safety, but is necessary for proper operation.

KEEP SHIELDS, GUARDS AND COVERS IN PLACE. These safety devices are provided to protect everyone from injury.

A DRYER SHOULD BE CONNECTED TO POWER FOR THREE (3) MINUTES before it is operated or before a program change is made. Operation or program changes, which occur during this "power up" period, are subject to loss in case of power interruption. After the initial three minutes, all programmed data is protected from power interruptions of any length and the customer's individual cycle is protected up to 3 seconds. This is done without batteries.

LEAVE THE ELECTRICAL POWER TO THE DRYER ON AT ALL TIMES except when necessary for service or other similar activities. The hour meter function adds only full hours to its reading. If the power is shut off every night, any fraction of an hour of time that is on the machine at that time will be lost. Turning the power off every night could also have some effect on the long-term life of the memory after a number of years. Turning power off occasionally won't affect the unit.

THIS DRYER IS EQUIPPED WITH AN OVER-TEMPERATURE THERMOSTAT located on the right side of the return lint hood assembly (open lower service door). Should the dryer cease to operate, refer to your "Service Procedure and Parts Data" book for instructions.

CHECK THIS THERMOSTAT WHEN INSTALLING DRYER to assure it is not tripped. Impacts such as rough handling in shipment, may trip the thermostat.

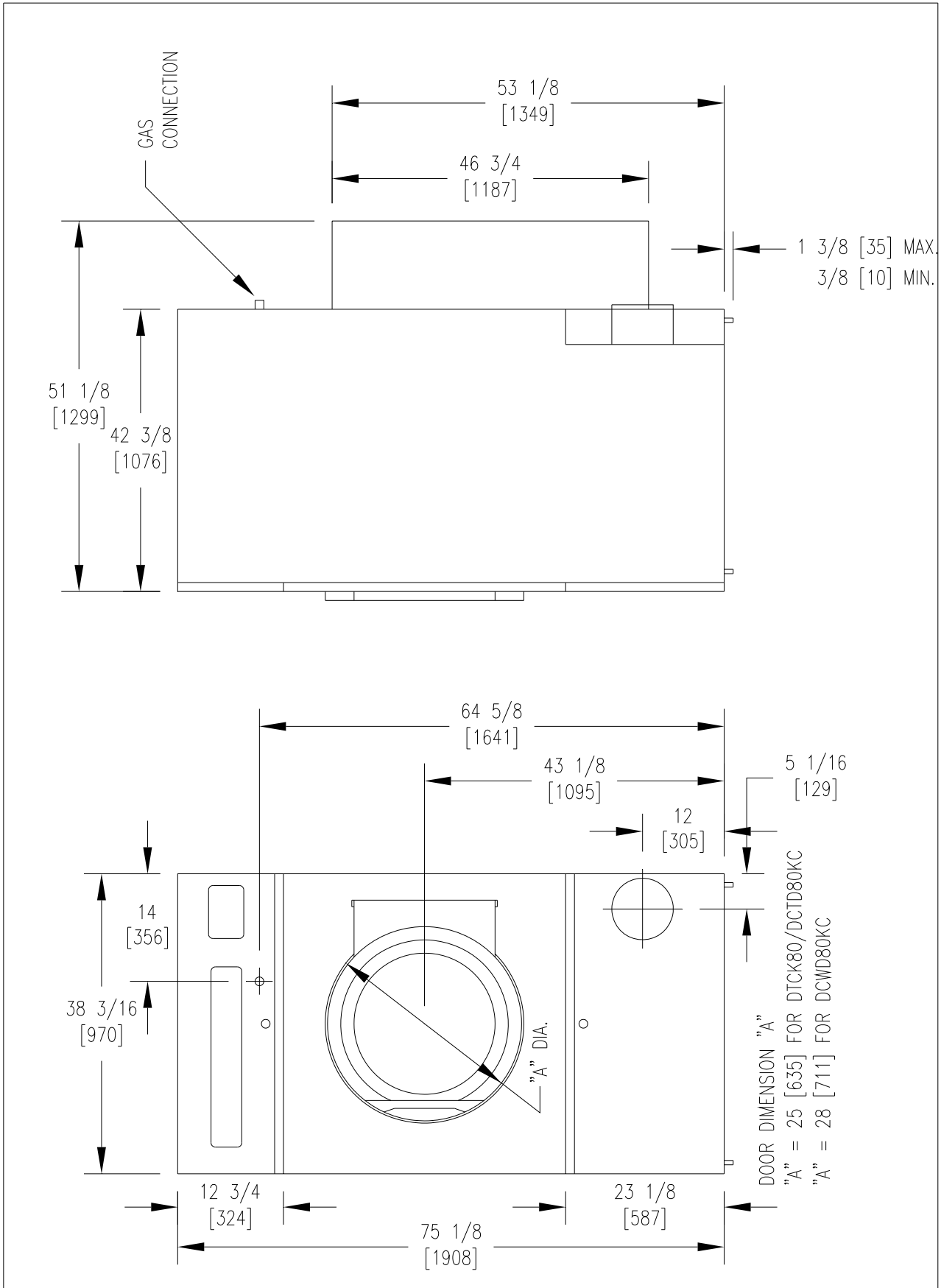

FIGURE 1 - 80# Dryer Dimensions, inches [mm].

INSTALLATION AND OPERATING INSTRUCTIONS COMMERCIAL DRYER

UNCRATING

1. Remove cardboard container and innerpack.
2. Complete the uncrating as described in the procedure listed on the instruction sheet taped to the loading door glass.

DRYER INSTALLATION

1. **CODE CONFORMITY.** All commercial dryer installations must conform with local codes or, in the absence of local codes, with the latest edition of the National Fuel Gas Code ANSI Z223. 1. Canadian installations must comply with current Standard CAN/CGA-B149 (.1 or .2) Installation Code for Gas Burning Appliances or Equipment, and local codes if applicable. The appliance, when installed, must be electrically grounded in accordance with the latest edition of the National Electric Code, ANSI/NFPA70, or, when installed in Canada, with Standard CSA C22.1 Canadian Electrical Code Part 1.

2. **INSTALLATION CLEARANCES:** This unit may be installed at the following alcove clearance. (millimeters)

- I. Left Side 0"
- II. Right Side 0"
- III. Back 18" (457) (Certified for 1" (25) clearance; however, 18" (457) clearance is necessary behind the belt guard to allow servicing and maintenance.)
- IV. Front 48" (1220) (to allow use of dryer)
- V. Top Refer to figure labeled "Vertical Clearance Dimensions".

AB. Certification allows 0" clearance at the top 1" (25) back from the front. However, a 1/2" (12) clearance is required to allow opening the upper service door.

CD. A 4" (102) clearance is required at the top between 1" (25) and 4" (102) from front.

E. A 10" (254) clearance is required from top at all other points.

- VI. Floor This unit may be installed upon a combustible floor.

*Units may be installed in direct contact with an adjacent dryer, providing allowance is made for opening upper and lower service doors.

Do not obstruct the flow of combustion and ventilation air.

Maintain minimum of 1" (25) clearance between duct and combustible material.

Refer to installation label attached to the inside surface of the upper door of the dryer for other installation information.

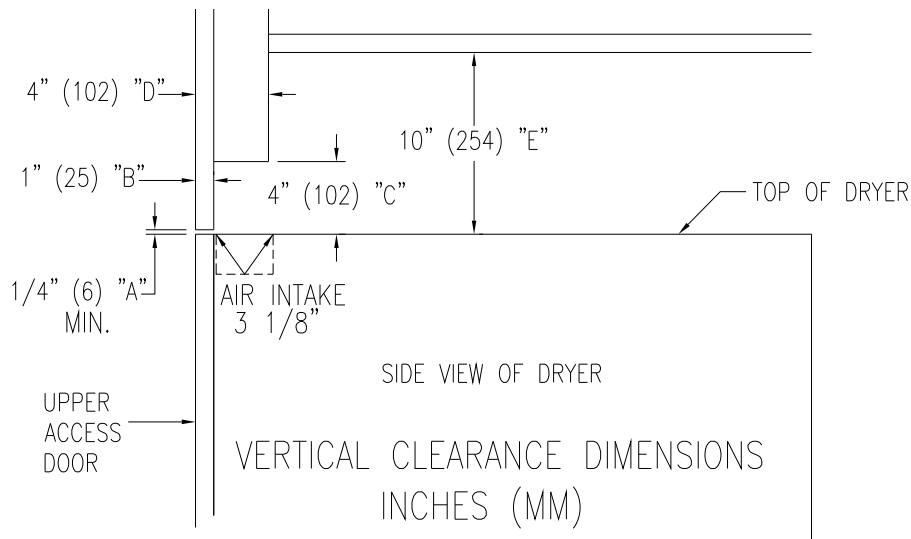

3. **MAKE-UP AIR.** Adequate make-up air (1200 CFM) must be supplied to replace air exhausted by dryers on all types of installations. Provide a minimum of 1.25 square foot make-up air opening to the outside for each dryer. This is a net requirement of effective area. Screens, grills or louvers, which will restrict the flow of air, must be considered. Consult the supplier to determine the free area equivalent for the grill being used.

The source of make-up air should be located sufficiently away from the dryers to allow an even airflow to the air intakes of all dryers. Multiple openings should be provided.

NOTE: The following considerations must be observed for gas dryer installations where dry cleaners are installed. The sources of all make-up air and room ventilation air movement to all dryers must be located away from any dry cleaners. This is necessary so that solvent vapors will not be drawn into the dryer inlet ducts. Dry cleaner solvent vapors will decompose in contact with an open flame such as the gas flame present in clothes dryers. The decomposition products are highly corrosive and will cause damage to the dryer(s), ducts and clothes loads.

4. **ELECTRICAL REQUIREMENTS.** (Refer to schematic and wiring diagram). This dryer is equipped with a reconnectable motor and control transformer for use on 208–240V–1PH–60Hz or 110–125V–1PH–60Hz. The control voltage is 24V, 60 Hz. The electrical power requirements necessary to operate the unit satisfactorily are listed on the serial plate located on the back panel of each dryer. The electrical connection should be made to the terminal in the control box on the rear of the unit, using a wire size adequate to handle the amperage and voltage listed on the serial plate, but never smaller than No.12 AWG wire. The ground lug must be connected to a good external ground.

Individual circuit breakers for each unit are recommended. The schematic and wiring diagram is located on the belt guard on the back of the machine.

5. **GAS REQUIREMENTS.** The complete gas requirements necessary to operate the dryer satisfactorily are listed on the serial plate located on the back panel of the dryer.

The inlet gas connection to the unit is 1/2-inch pipe thread. However, the size of the piping to supply the dryer should be determined by reference to the National Fuel Gas Code ANSI Z223.1A and consultation with the local gas supplier.

A joint compound resistant to the action of liquefied petroleum gases should be employed in making pipe connections.

A drip tee should be provided in the gas piping entering the unit to catch dirt and other foreign articles.

All pipe connections should be checked for leakage with soap solution. Never check with an open flame.

For altitudes above 2,000 feet (610m) it is necessary to derate the BTU input. Contact your local distributor for instructions.

L.P. gas conversion kits are available for this dryer. Contact your local distributor.

6. **PRESSURE TESTING.** The dryer and its individual shutoff valve must be disconnected from the gas supply piping system during any pressure testing of that system at test pressures in excess of 1/2 psig.

The dryer must be isolated from the gas supply piping system by closing its individual manual shutoff valve during any pressure testing of the gas supply piping system at test pressures equal to or less than 1/2 psig.

7. **EXHAUST INSTALLATION.** (Refer to Figure 2 at the end of section 7.) Exhausting of the dryer(s) should be planned and constructed so that no air restrictions occur. Any restriction due to pipe size or type of installation can cause slow drying time, excessive heat, and lint in the room.

From an operational standpoint, incorrect or inadequate exhausting can cause a cycling of the high limit thermostat, which shuts off the main burners and results in inefficient drying.

Individual exhausting of the dryers is recommended. All heat, moisture, and lint should be exhausted outside by attaching a pipe of the proper diameter to the dryer adapter collar and extending it out through an outside wall. This pipe must be very smooth on the inside, as rough surfaces tend to collect lint, which will eventually clog the duct and prevent the dryer from exhausting properly. All elbows must be smooth on the inside. All joints must be made so the exhaust end of one pipe is inside the next one downstream. The addition of an exhaust pipe tends to reduce the amount of air the blower can exhaust. This does not affect the dryer operation if held within practical limits. For the most efficient operation, it is recommended that no more than 20 feet (6m) of straight 8" diameter pipe be used with two right angle elbows. When more than two elbows are used, two feet of straight pipe should be removed for each additional elbow. No more than four right angle elbows should be used to exhaust a dryer.

Maintain a minimum of 1" (25) clearance between duct and combustible material.

If the exhaust pipe passes through a wall, a metal sleeve of slightly larger diameter should be set in the wall and the exhaust pipe passed through this sleeve. This practice is required by some local codes and is recommended in all cases to protect the wall. This type of installation should have a means provided to prevent rain and high winds from entering the exhaust when the dryer is not in use. A hood with a hinged damper can be used for this purpose. Another method would be to point the outlet end of the pipe downward to prevent entrance of wind and rain. In either case, the outlet should be kept clear, by at least 24" (610m), of any objects, which would cause an air restriction.

Never install a protective screen over the exhaust outlet.

When exhausting a dryer straight up through a roof, the overall length of the duct has the same limits as exhausting through a wall. A rain cap must be placed on top of the exhaust and must be of such a type as to be free from clogging. The type using a cone shaped "roof" over the pipe is suitable for this application.

Exhausting the dryer into a chimney or under a building is not permitted under any conditions. In both cases, there is a danger of lint build-up, which can be highly combustible.

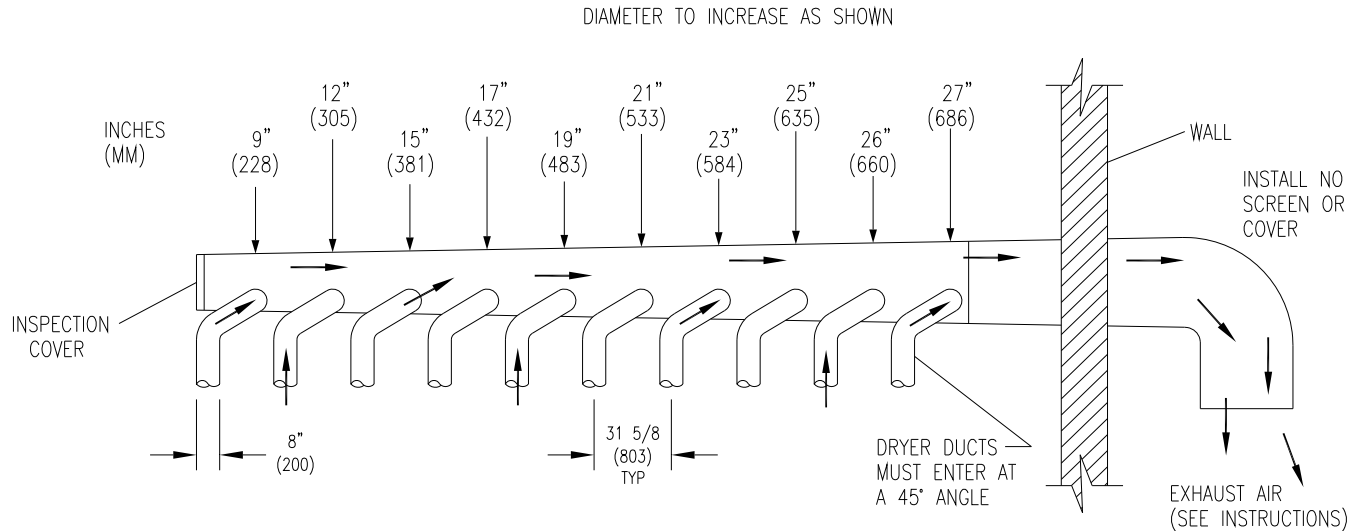

FIGURE 2- Dryer Exhausting Using A Main Discharge Duct.

Installation of several dryers, where a main discharge duct is necessary, will need the following considerations for installation (see Fig. 2). Individual 8" ducts from the dryers into the main discharge duct should be at a 45-degree angle in the direction of discharge airflow.

NOTE: Never install the individual 8" ducts at a right angle into the main discharge duct. The individual ducts from the dryers can enter at the sides or bottom of the main discharge duct. Figure 2 indicates the various round main duct diameter to use with the individual dryer ducts. The main duct can be rectangular or round, provided adequate airflow is maintained. For each individual dryer, the total exhausting (main discharge duct plus duct outlet from the dryer) should not exceed the equivalent of 20 feet (6m) and two elbows. The diameter of the main discharge duct at the last dryer must be maintained to exhaust end.

NOTE: A small diameter duct will restrict airflow; a large diameter duct will reduce air velocity -- both contributing to lint buildup. An inspection door should be provided for periodic clean out of the main duct.

8. **DRYER IGNITION (SOLID STATE IGNITION).** The solid-state ignition system lights the main burner gas by spark. The gas is ignited and burns only when the gas-valve relay (in the electronic controller) calls for heat. The procedure for first-time starting of a dryer is as follows:

A. First, review and comply with the "Warnings About Use and Operation" found on the inside front cover of this manual. Be sure the electrical power supply is connected correctly. The white wire is to be connected to the white wire (common) in the junction box and the black wire to the black wire (power leg). The dryer **MUST** be properly grounded.

B. Make sure all gas supply lines are purged of air. Close the main gas shut-off valve and wait for five minutes before turning the valve back on.

C. Turn on the main electrical power switch. The dryer may be started by following the "Operating Instructions" found later in this manual.



D. Natural gas and liquefied petroleum gas fired dryers both operate in the same manner. When the thermostat contacts are closed (indicating a demand for heat), the solid-state ignition control will automatically supply energy to the spark gap and to the redundant gas valve. Spark will continue until a flame is detected by the sensing probe, but not longer than 10 seconds. If the gas fails to ignite within 10 seconds the gas valve closes. It is then necessary to interrupt electrical power to the ignition system before making another attempt at lighting the burners. This can be done by opening the dryer door and allowing the dryer to come to a stop for 15 seconds, then closing the door and actuating the push-to start button. The dryer will then repeat the ignition trial cycle.

9. **MAIN BURNER ADJUSTMENT.** The primary air shutter of each main burner must be properly adjusted for the correct air-gas ratio. Adjust the shutter by closing it sufficiently to give a blue flame with a yellow tip. Next open the shutter until the yellow tips are at a minimum. Securely lock each shutter in position by tightening the screw after adjusting the shutter.

DRYER SHUTDOWN

1. **SOLID STATE IGNITION MODELS.** To render the dryer inoperative, turn off the main gas shut-off valve and disconnect power to the dryer.

OPERATING INSTRUCTIONS

1. Deposit coins, tokens or debit card to satisfy vend price display of idle dryer. Each deposit decreases vend price until display changes to show time purchased. WARM or LOW light illuminates.
2. Select drying cycle. Other cycle selections may be made now or later by pressing the appropriate key (button).
3. Close the loading door. Press  and the dryer will start. "Seconds" goes to . "Minutes" is rounded up and will count down each minute. The colon flashes on and off indicating the timer is counting down.
4. Clothes should be removed promptly after the cycle is completed to prevent excessive wrinkling.

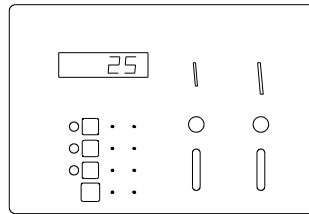

VEND PRICE

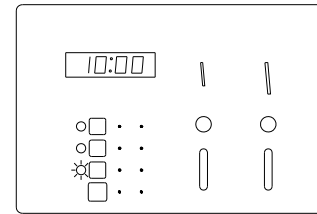

MINUTES : SECONDS
PURCHASED

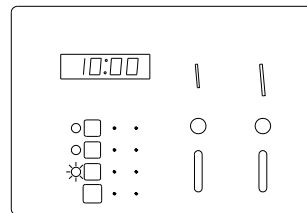

START

Once started, the "timer" cannot be stopped. However, extra coins will be acknowledged by adding time to the display. The dryer may be stopped by opening the loading door, which interrupts the drive motor and gas burners. Close the loading door and push  to restart the dryer.

Cool-down time (owner programmable) is always part of the cycle time and is purchased by the customer. For example, if cool-down time is 2 minutes, the last 2 minutes of the cycle will have no heat.

DESCRIPTION OF CONTROLS

Credit for coins deposited, dryer time and temperature are controlled by an electronic controller.

The large digital display shows vend price of an idle dryer, time purchased after coins are deposited, temperature, and program information.

The three red indicator lights show the drying temperature selected. This selection may be made anytime.

The drying temperature will be displayed when the start switch and the switch for the selected temperature are pressed at the same time.

All programmed data is protected from power interruption of any length and the customer's individual cycle is protected for up to 3 seconds. This is done without batteries.

The 3 temperature buttons and the start button become programming switches when the controller is in the program mode as described on page 10.

EASY CARD MODELS

Some Dexter dryers are factory equipped with a card reader that is used with Dexter's Easy Card debit card system. The card reader signals the dryer control when money is debited from the user's card account to satisfy the price of the dry time. The dryer's pricing and the Easy Card system pricing are completely independent of each other and must be programmed separately and coordinated. Refer to the instructions that came with the Easy Card system for complete information.

PROGRAMMING:

(Instructions on Page 10 and 11)

All operating parameters (vend price, temperatures, cool-down times, etc.) are adjustable. In addition, several displays of information are available from the controller (Money audits, hours run, dryer temperature).

The dryer is ready to run, from the factory, with the following pre-programmed data:

Temperature, HOT or HIGH:	175 (degrees F) / 78 (degrees C)
Temperature, MEDIUM:	150 (degrees F) / 63 (degrees C)
Temperature, WARM or LOW:	125 (degrees F) / 48 (degrees C)
Vend Price:	25 (cents)
Time for Left Coin:	3:20 (3 minutes, 20 seconds for a dime) (doesn't apply to single-coin models)
Time for Right Coin:	8:00 (8 minutes for a quarter)
Time of Free Vend:	8:00 ("Free Dry" cycle is 8 minutes)
Cool-down Time, HOT or HIGH:	2:00 (Cool-down time in HOT or HIGH is 2 minutes)
Cool-down Time, MEDIUM:	2:00 (Same as above, except MEDIUM)
Cool-down Time, WARM or LOW:	2:00 (Same as above, except WARM or LOW)
Temperature Scale	F degrees
Decimal Point Display	ON
Seconds on Display	OFF

All of the above data can be easily changed by the owner. The changes are made by the 4 keys or buttons on the front of the control panel.

CHANGING PROGRAM DATA

Put dryer in PROGRAM mode as instructed on page 10. The dryer remains in the PROGRAM mode until one of these actions occur:

- The switch is actuated again.
- The seventeenth step is completed and the START switch is pushed following the seventeenth step.
- Programming is stopped for about a minute.
- The loading door is closed.

Observe the displayed value in each step. If no change is required, press START to advance to the next program step. If a change is required the values are made larger by the HOT or HIGH button, smaller by the MED button. The hour meter and money audit can be reset to zero if WARM or LOW is pressed.



Note that after any reset or program change it is necessary to advance to the next step by pressing START to enter the revision. OTHERWISE THE VALUE WILL REMAIN AS IT WAS BEFORE THE ALTERATION.

PROGRAMMING INSTRUCTIONS:

(To switch to program mode.)

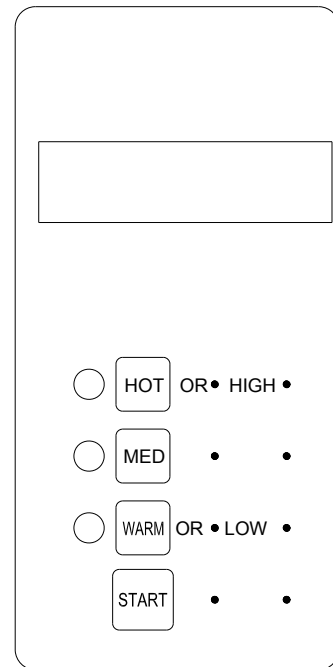
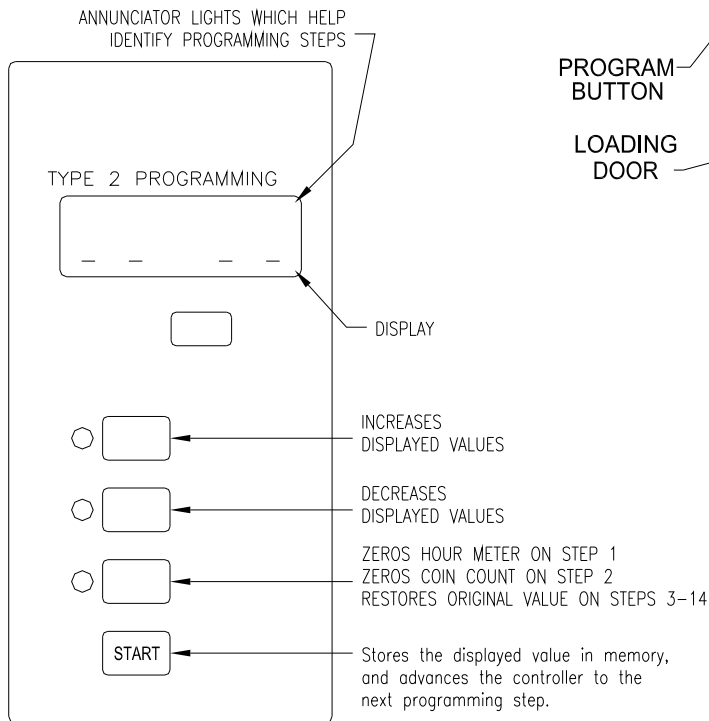
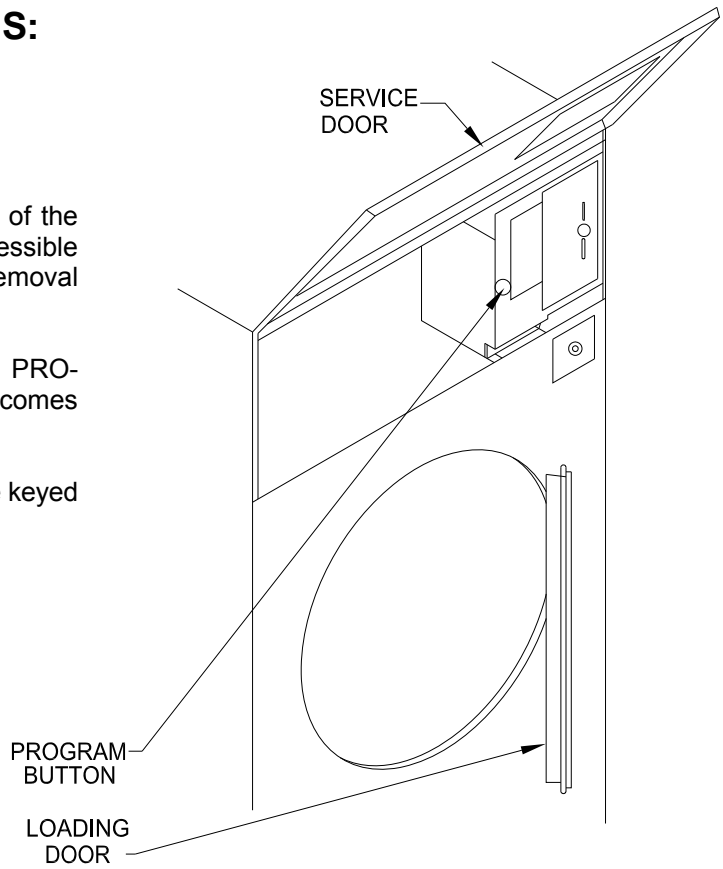
1. Unlock and open the upper service door.
2. Open the loading door.
3. Push the Program Button found just to the left of the WARM or LOW cycle light. The Button is accessible through a hole in control mounting plate, after removal of bright metal plug.
4. The control switches to PROGRAM mode. In PROGRAM mode, the membrane switch keypad becomes a 4-switch programming tool.
5. The ACTUAL NUMERICAL VALUES desired are keyed in as explained on P.11.



IMPORTANT: Please remember to push  to actually enter (store in memory) new data. If you merely change the display, memory hasn't yet been changed -- only  will actually change the memory!

ORDER OF PROGRAMMING STEPS

CYCLE LIGHTS	DISPLAY	PROGRAMMING STEP	DESCRIPTION	OPTIONS/RANGE OF LIMITS
• H	— — —	HOURMETER	Displays hours of "timer" operation	May be reset to zero
• M	— — —	MONEY AUDIT	Number of pulses from acceptor or Easy Card reader.	May be reset to zero
• W	— — —	TEMPERATURE; HOT or HIGH	Median operating temp. - Hot or High (Regular).	150 - 190°F / 63 - 87°C
• H	— — —	TEMPERATURE; MEDIUM	Median operating temp. - Medium (Permanent Press).	120 - 170°F / 45 - 75°C
• M	— — —	TEMPERATURE; WARM or LOW	Median operating temp. - Warm or Low (Delicate).	110 - 150°F / 39 - 63°C
• W	— — —	LEFT COIN VALUE	Value of coin/token deposited through left acceptor (dual coin models) in 1¢ increments. For Easy Card systems, set to default.	Must be value of coins through left acceptor
	— — —	RIGHT COIN VALUE	Value of coin/token deposited through right acceptor (all models) in 1¢ increments. For Easy Card systems, set to default.	Must be value of coins through right acceptor
	— — —	VEND PRICE	Money required to start the dryer in 1¢ increments.	00 through 9999 (cents) (00 causes "Free Vend")
	— — —	TIME FOR LEFT COIN	Minutes and seconds awarded for one coin deposited through the left coin acceptor (dual coin models)	00 through 99 min: 55 sec
	— — —	TIME FOR RIGHT COIN	Minutes and seconds awarded for one coin deposited through the right coin acceptor (all models)	00 through 99 min: 55 sec
	— — —	TIME OF FREE VEND	Minutes and seconds of "Free" dry (If free dry feature is used - see vend price above.)	00 through 99 min: 55 sec
• H	— — —	COOL-DOWN TIME; HOT or HIGH	Minutes and seconds of cool-down; Hot or High cycle	00 through 10 min
• M	— — —	COOL-DOWN TIME; MEDIUM	Minutes and seconds of cool-down; Medium cycle	00 through 10 min
• W	— — —	COOL-DOWN TIME; WARM or LOW	Minutes and seconds of cool-down; Warm or Low cycle	00 through 10 min
	— — —	TEMPERATURE SCALE	Sets Temperature Display to °F or °C	F or C
	— — —	DISPLAY: DECIMAL POINT	Displays decimal point in prices.	OFF or ON
	— — —	DISPLAY: SECONDS	Displays time remaining in minutes:00 or in minutes:seconds.	OFF or ON

Setting the Electronic Coin Acceptor Switches

- 1) The electronic coin acceptor has switches depending on the coins and country. See Table 1, Table 2, or Table 3 for available values of the left and right coin inputs for the available countries.
WARNING: TURN POWER OFF BEFORE AND LEAVE POWER OFF WHEN CHANGING THE SWITCHES OF THE ELECTRONIC COIN ACCEPTOR.
- 2) Turn power back on and test coins to ensure proper operation.

Table 1

Acceptor P/N	Country	Left Coin	Right Coin	SWs 1-8	SWs 9-16
9021-014-002	Canada	25¢		↓↓↑↑↑↑↑↓	↓↑↑↑↑↑↑↓
	Canada		\$1	↑↑↓↓↑↑↑↓	↓↑↑↑↑↑↑↓
	Canada		\$2	↑↑↑↑↓↓↓↓	↓↑↑↑↑↑↑↓
	Canada		\$1 + \$2	↑↑↓↓↓↓↓↓	↓↑↑↑↑↑↑↓
	Canada	25¢	\$1	↓↓↓↓↑↑↑↓	↓↑↑↑↑↑↑↓
	Canada	25¢	\$1 + \$2	↓↓↓↓↓↓↓↓	↓↑↑↑↑↑↑↓
	Japan	100¥		↓↓↑↑↑↑↑↓	↑↓↑↑↑↑↑↓
	Japan		500¥	↑↑↓↓↑↓↓↓	↑↓↑↑↑↑↑↓
	Japan	100¥	500¥	↓↓↓↓↑↓↓↓	↑↓↑↑↑↑↑↓
	Taiwan	10NT		↓↓↑↑↑↑↑↓	↑↑↓↑↑↑↑↓
	Taiwan		50NT	↑↑↓↓↑↓↓↓	↑↑↓↑↑↑↑↓
	Taiwan	10NT	50NT	↓↓↓↓↑↓↓↓	↑↑↓↑↑↑↑↓
	Korea	500W		↓↓↑↑↑↑↑↓	↑↑↑↓↑↑↑↓
		Greenwald 118-1 Token		↑↑↑↑↑↑↑↓	↑↑↑↑↓↑↑↓
		Greenwald 118-5 Token		↑↑↑↑↑↑↑↓	↑↑↑↑↓↑↑↓
	U.S.A.	25¢		↓↓↑↑↑↑↑↓	↑↑↑↑↑↑↓↓
	U.S.A.		\$1	↑↑↓↓↑↑↑↓	↑↑↑↑↑↑↓↓
	U.S.A.	25¢	\$1	↓↓↓↓↑↑↑↓	↑↑↑↑↑↑↓↓

Switches ↑=up/on, ↓=down/off

Note: Coins and tokens in the left coin column will result in one pulse to the left coin input.

Note: The \$1, 500¥, 50NT, and \$10 coins in the right coin column will result in one pulse to the right coin input, while the \$2 coin in the right coin column will result in two pulses to the right coin input.

Note: Acceptance of multiple coins per country and multiple tokens is allowed. Only the down/off setting for each coin and token is required to accept that coin or token.

Table 2 for acceptors with spec 109

Acceptor P/N	Country	Left Coin	Right Coin	SWs 1-8	SWs 9-16	
9021-015-002	Australia	10¢		↓↓↑↑↑↑↑↓	↑↓↑↑↑↑↑↓	
	Australia	20¢		↑↑↓↓↑↑↑↓	↑↓↑↑↑↑↑↓	
	Australia		\$1	↑↑↑↑↓↓↑↓	↑↑↓↑↑↑↑↓	
	Australia		\$2	↑↑↑↑↑↑↓↓	↓↓↓↑↑↑↑↓	
	Australia		\$1 + \$2	↑↑↑↑↓↓↓↓	↓↓↓↑↑↑↑↓	
	Australia	10¢	\$1	↓↓↑↑↓↓↑↓	↑↓↓↑↑↑↑↓	
	Australia	10¢	\$1 + \$2	↓↓↑↑↓↓↓↓	↓↓↓↑↑↑↑↓	
	Australia	20¢	\$1	↑↑↓↓↓↓↑↓	↑↓↓↑↑↑↑↓	
	Australia	20¢	\$1 + \$2	↑↑↓↓↓↓↓↓	↓↓↓↑↑↑↑↓	
	New Zealand	10¢		↓↓↑↑↑↑↑↓	↑↓↑↑↑↑↑↓	
	New Zealand	20¢		↑↑↓↓↑↑↑↓	↑↓↑↑↑↑↑↓	
	New Zealand		\$1	↑↑↑↑↓↓↑↓	↑↑↑↓↑↑↑↓	
	New Zealand		\$2	↑↑↑↑↑↑↓↓	↓↑↑↓↑↑↑↓	
	New Zealand		\$1 + \$2	↑↑↑↑↓↓↓↓	↓↑↑↓↑↑↑↓	
	New Zealand	10¢	\$1	↓↓↑↑↓↓↑↓	↑↓↓↑↑↑↑↓	
	New Zealand	10¢	\$1 + \$2	↓↓↑↑↓↓↓↓	↓↓↓↑↑↑↑↓	
	New Zealand	20¢	\$1	↑↑↓↓↓↓↑↓	↑↓↓↑↑↑↑↓	
	New Zealand	20¢	\$1 + \$2	↑↑↓↓↓↓↓↓	↓↓↓↑↑↑↑↓	
	Hong Kong	\$5		↓↓↓↓↑↑↑↓	↑↑↑↑↓↑↑↓	
	Hong Kong		\$10	↑↑↑↑↓↓↑↓	↑↑↑↑↓↑↑↓	
	Hong Kong	\$5	\$10	↓↓↓↓↓↓↑↓	↑↑↑↑↓↑↑↓	
			Greenwald 118-1 Token		↑↑↑↑↑↑↑↓	↑↑↑↑↑↓↑↓
			Greenwald 118-5 Token		↑↑↑↑↑↑↑↓	↑↑↑↑↑↑↓↓

Switches ↑=up/on, ↓=down/off

Note: The 10¢ and \$5 coins and tokens in the left coin column will result in one pulse to the left coin input, while the 20¢ coins in the left column will result in two pulses to the left coin input.

Note: The \$1 and \$10 coins in the right coin column will result in one pulse to the right coin input, while the \$2 coin in the right coin column will result in two pulses to the right coin input.

Note: Acceptance of multiple coins per country and multiple tokens is allowed. Only the down/off setting for each coin and token is required to accept that coin or token.

Table 3 for acceptors with spec 311

Acceptor P/N	Country	Left Coin	Right Coin	SWs 1-8	SWs 9-16	
9021-015-002	Australia	10¢		↓↑↑↑↑↑↓	↑↑↓↑↑↑↑↑	
	Australia	20¢		↑↑↓↑↑↑↓	↑↑↓↑↑↑↑↑	
	Australia		\$1	↑↑↑↑↓↑↓	↑↑↓↑↑↑↑↑	
	Australia		\$2	↑↑↑↑↑↓↓	↓↑↓↑↑↑↑↑	
	Australia		\$1 + \$2	↑↑↑↑↓↑↓	↓↑↓↑↑↑↑↑	
	Australia	10¢	\$1	↓↑↑↑↓↑↓	↑↑↓↑↑↑↑↑	
	Australia	10¢	\$1 + \$2	↓↑↑↑↓↑↓	↓↑↓↑↑↑↑↑	
	Australia	20¢	\$1	↑↑↓↑↓↑↓	↑↑↓↑↑↑↑↑	
	Australia	20¢	\$1 + \$2	↑↑↓↑↓↑↓	↓↑↓↑↑↑↑↑	
	New Zealand	10¢		↓↑↑↑↑↑↓	↑↑↑↓↑↑↑↑	
	New Zealand	20¢		↑↑↓↑↑↑↓	↑↑↑↓↑↑↑↑	
	New Zealand	50¢		↑↑↑↑↑↑↓	↑↓↑↓↑↑↑↓	
	New Zealand		\$1	↑↑↑↑↓↑↓	↑↑↑↓↑↑↑↑	
	New Zealand		\$2	↑↑↑↑↑↓↓	↓↑↓↑↑↑↑↑	
	New Zealand		\$1 + \$2	↑↑↑↑↓↑↓	↓↑↓↑↑↑↑↑	
	New Zealand	10¢	\$1	↓↑↑↑↓↑↓	↑↑↑↓↑↑↑↑	
	New Zealand	10¢	\$1 + \$2	↓↑↑↑↓↑↓	↓↑↓↑↑↑↑↑	
	New Zealand	20¢	\$1	↑↑↓↑↓↑↓	↑↑↑↓↑↑↑↑	
	New Zealand	20¢	\$1 + \$2	↑↑↓↑↓↑↓	↓↑↓↑↑↑↑↑	
	Hong Kong	\$5		↓↑↓↑↑↑↓	↑↑↑↑↓↑↑↑	
	Hong Kong		\$10	↑↑↑↑↓↑↓	↑↑↑↑↓↑↑↑	
	Hong Kong	\$5	\$10	↓↑↓↑↓↑↓	↑↑↑↑↓↑↑↑	
			Greenwald 118-1 Token		↑↑↑↑↑↑↓	↑↑↑↑↑↓↑↑
			Greenwald 118-5 Token		↑↑↑↑↑↑↓	↑↑↑↑↑↓↑

Switches ↑=up/on, ↓=down/off

Note: The 10¢ and \$5 coins and tokens in the left coin column will result in one pulse to the left coin input, while 20¢ coins in the left column will result in two pulses to the left coin input. The 50¢ coin in the left column will result in five pulses to the left coin input.

Note: The \$1 and \$10 coins in the right coin column will result in one pulse to the right coin input, while the \$2 coin in the right coin column will result in two pulses to the right coin input.

Note: Acceptance of multiple coins per country and multiple tokens is allowed. Only the down/off setting for each coin and token is required to accept that coin or token.

SERVICING DRYER

CAUTION: Label all wires prior to disconnection when servicing controls. Wiring errors can cause improper and dangerous operation. Verify proper operation after servicing.

ATTENTION. Lors des opérations d'entretien des commandes, étiqueter tous les fils avant de les déconnecter. Toute erreur de câblage peut être une source de danger et de panne.

PREVENTIVE MAINTENANCE INSTRUCTIONS

DAILY

1. Clean lint screen. Use soft brush if necessary.
2. Check lint screen for tears. Replace if necessary.
3. Clean lint from lint screen compartment.

MONTHLY

1. Remove lint accumulation from end bells of motor.
2. Remove lint from meter compartment and meter mechanism.
3. Remove lint and dirt accumulation from top of the dryer and all areas above, below and around the burners and burner housing. Failure to keep this portion of the dryer clean can lead to a build-up of lint creating a fire hazard.
4. Place a few drops of light oil on clothes door hinge.

QUARTERLY

1. Check belts for looseness, wear or fraying.
2. Inspect gasket of door glass for excessive wear.
3. Check tightness of all fasteners holding parts to support channel.
4. Check tightness of all set screws.
5. Inspect impeller for tightness of blades to hub.
6. Check tightness of tumbler shaft retaining cap screw.
7. Remove back inspection plate and check tumbler thru-bolts for tightness.
8. Remove lint accumulation from primary air ports in burners.
9. Grease pivot pins and tension arms where in contact with each other.
10. Apply a few drops of oil to each spacer tube on the tension arm assembly.

SEMI-ANNUALLY

1. Remove and clean main burners.
2. Remove all orifices and examine for dirt and hole obstruction.
3. Remove all lint accumulation. Remove front panel, lint screen housing and remove lint accumulation.

ANNUALLY

1. Check intermediate pulley bearings for wear.
2. Check and remove any lint accumulation from exhaust system.